

The characteristics of cutting forces in the micro-milling of AISI D2 steel[†]

Cheng-Zhe Jin¹, Ik-Soo Kang², Jin-Hyo Park³, Su-Hoon Jang³ and Jeong-Suk Kim^{4,*}

¹Engineering Technology Center for High Speed Machining, Shenyang Ligong University, Shenyang, People's China

²School of Mechanical Engineering, Pusan National University, Jangjeon-dong, Geumjeong-gu, Busan 609-735, Korea

³Graduate School of Mechanical Engineering, Pusan National University, Jangjeon-dong, Geumjeong-gu, Busan 609-735, Korea

⁴School of Mechanical Engineering, ERC/NSDM, Pusan National University, Jangjeon-dong, Geumjeong-gu, Busan 609-735, Korea

(Manuscript Received December 22, 2008; Revised June 11, 2009; Accepted June 16, 2009)

Abstract

The interaction effect of parameters to surface topography and cutting forces is investigated, and the magnitudes of these parameters are determined in the micro-milling of AISI D2 steel. The results show that the feed per tooth has a prominent impact on the surface topography. Due to the low feed per tooth to cutting edge radius ratio, a high surface roughness and a high amount of burrs are obtained in micro-milling. In micro cutting, the cutting forces present are small; in addition, the radial thrust cutting forces are greater than the principal cutting forces. This research proves that the micro-milling process can be applied to the manufacturing of AISI D2 steel micro parts and presents experimental evidence and possible solutions to the cutting parameters.

Keywords: Cutting forces; Cutting parameters; Micro-milling; Surface topography

1. Introduction

Mechanical machining processes such as cutting, grinding, drilling, and polishing have been playing an important role in manufacturing work pieces and have allowed for more precision machining. Micro-milling using end mills of diameters in the sub-millimeter range, a process of creating features measured in micrometers, is rapidly growing in advanced industries [1]. This process can cost-effectively produce micro parts because equipment costs are relatively low compared with other processes [2]. The micro-milling process is a flexible process and is able to create more complex microstructures where the surface topography and cutting forces are dependent upon the cutting

parameters. In many applications, it is important to improve the surface quality in the fabrication of micro components.

Some researchers have made contributions related to the surface topography and cutting forces. Chan et al. [3] performed a series of cutting experiments while cutting metal matrix composites by adopting different process parameters. They concluded that the surface roughness increases with an increased cutting speed. Katayama et al. [4] studied the formation of the built-up edge (BUE) and its effects on the machined surface roughness by means of cutting various steel materials, and they observed that the surface roughness of both dual-phase and multi-phase materials is worse than that of single-phase materials. Kim and Kim [5] showed the analytical differences in the cutting forces between the macro- and micro-cutting processes. Kang et al.'s cutting force model [6, 7], which considered the cutting edge radius of a micro tool, is

[†] This paper was recommended for publication in revised form by Associate Editor Dae-Eun Kim

*Corresponding author. Tel.: +82 51 510 2334, Fax.: +82 51 510 2334

E-mail address: juskim@pusan.ac.kr

© KSME & Springer 2009

simulated and investigated through the newly developed tool dynamometer for micro-end-milling. Tansel et al. [8] studied the relationship between the cutting force characteristics and tool usage (wear) in the micro-end-milling operation for aluminum and steel. Most published papers concerned with micro-milling are focused on ductile materials, such as brass, copper and aluminum, and provide valuable results regarding the micro-milling process. However, little research has been published regarding the micro-milling of steel with tungsten carbide tools, wherein an adapted process strategy is very important to machine-hardened steel. The mechanical properties of the work-piece material are excellent toughness and outstanding wear resistance. In this paper, the influence of cutting parameters on the surface topography and cutting forces is demonstrated in the micro-milling of AISI D2 steel.

2. Cutting parameters analysis

Micro-scale milling is not simply downsized from the conventional operation of milling but has its own characteristics, such as size effect, cutting edge radius, and minimum chip thickness [9]. In slot-end milling operations, the complete set of cutting parameters is constituted by the cutting speed and by the axial depth of cut and feed per tooth, which defines the chip load. In particular, an investigation of the minimum chip thickness is very important in achieving more accurate machining. In conventional cutting, cutting edge radius is of no concern because it is so small compared with a cut with a depth of a few millimeters. On the other hand, the rake angle is a negative value when the uncut chip thickness is less than the cutting edge radius. This might cause ploughing and a poor surface, or sometimes burnishing and a shiny surface, depending on the uncut chip thickness. By reducing the dimensions of the tool, the dimensions of the material removed at each tooth pass are also necessarily reduced. The grain size of the work material, however, is not reduced accordingly. Therefore, in micro-milling, the chip formation comprises several grains, and the chip forms within a few or even a single grain at a time, as is shown in Fig. 1. This phenomenon is common to all micro-cutting processes and addressed as the size effect of the grain to the uncut chip thickness. When the grain size is greater than the uncut chip thickness, the spring back of the work-piece material becomes an important factor.

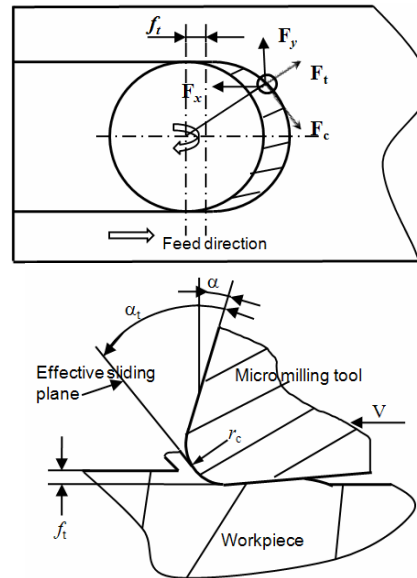

Fig. 1. Simplification of the micro-milling process. (F_x : feed direction cutting force; F_y : normal direction cutting force; F_c : principal forces; F_t : thrust forces; f_t : feed per tooth; r_c : cutting edge radius; α : rake angle; α_e : effective rake angle; and V : cutting speed)

The geometric configuration of micro-milling tools is different from that of conventional milling tools. The shank diameter is absolutely larger than the cutter diameter, and a soft connection is required in order to avoid stress concentrations. Thus, a much longer portion of the tool, than that required for the aspect ratio of the features to be machined, is characterized by a small diameter. While the machining accuracy in the direction of the spindle axis (the Z direction in a three-axis vertical milling machine) is determined by the accuracy of the axial depth of the cut, the accuracy in the orthogonal plane to the spindle axis (the X-Y plane in a three-axis milling machine) is primarily governed by tool deflections [10].

In fact, the capabilities of the tool manufacturing process are limited with respect to the minimum obtainable cutting edge radius, which is in the order of $1\ \mu\text{m}$ up to $4\ \mu\text{m}$ [11]. Therefore, the cutting edge radius is not consistently scaled with the tool diameter, and the cutting edge cannot be assumed to be perfectly sharp. This is commonly referred to as the size effect of the cutting edge radius. As a result, the uncut chip thickness is often smaller than the cutting edge radius, causing a highly negative rake angle, as is shown in Fig. 1. The effect of the cutting edge radius on the shear angle has been investigated during or-

thogonal cutting in [12], where it was found that the blunt cutting edge increased the specific cutting forces. Above a certain ratio of the uncut chip thickness to the cutting edge radius, the ploughing action is expected to dominate, and the thrust cutting forces are increased. In micro-milling, the selection of cutting parameters should be based on the estimation of surface topography, cutting forces, and the accuracy of the machined parts.

3. Micro-milling experiments

3.1 Experimental equipments

Fig. 2 illustrates the experimental setup for the machining tests. An air turbine-driven high-speed spindle, which can provide a rotational speed of up to 120,000 rpm with a run out of less than 1 μm , was mounted to the micro-milling stage. The Z-axis moves vertically with respect to the work piece, and the X-Y stage moves horizontally to achieve the desired depth of cut and feed rate. The maximum positioning accuracy was limited to that of the micro-milling stage. The applied micro-milling tools were solid carbide micro-end mills with a diameter (D) of 200 μm , helix angle of 30°, and cutting edge radius of 1.0 μm (Fig. 3). The work-piece material was AISI D2 steel (25 HRC).

3.2 Experimental purpose and method

The minimum chip thickness depends on the cutting edge radius and the physical relationship between a tool and a work-piece. According to different cutting conditions, it is possible to obtain different surface topographies and cutting forces in the micro-milling of AISI D2 steel. These surface topographies have a certain regulation, and the machined surfaces are measured using a non-contact surface roughness profiler along with a contact surface profiler. The work piece was attached to a micro-tool dynamometer, where the cutting force signals were digitized and stored simultaneously using a digital oscilloscope and a charge amplifier at the same sampling rates. Several tests were then conducted to determine the stable conditions.

Previously, the work-piece surface was completed using a 1 mm milling tool. The machining strategy is displayed in Fig. 4. To avoid ramping, the tool is positioned outside of the work piece, and then slots were milled with the full tool diameter being engaged.

The cutting parameters used are shown in Table 1. The experiments were performed without a lubricant.

3.3 Initial contact detection

Various micro-tools have to be used during the experiments on the micro-milling of AISI D2 steel. The origin coordinates of the X and Y axes may not be affected by a tool change because the machine generally stores the coordinates. In addition, the center of all the applied tools can be reasonably assumed to be

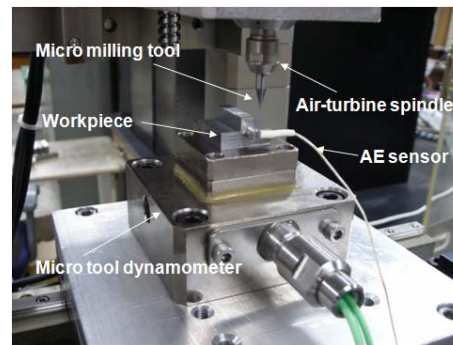

Fig. 2. Experimental setup for micro milling.



Fig. 3. The applied micro-cutting tool with a high-speed spindle.

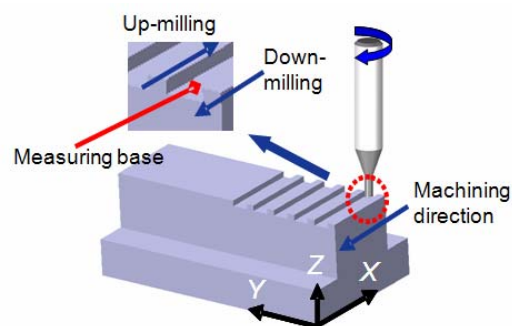

Fig. 4. Machining method.

Table 1. Experimental cutting parameters.

No.	A_d (μm)	Feed rate (mm/min)	f_t ($\mu\text{m}/\text{tooth}$)	Spindle speed (rpm)
1	10	60	0.25	120,000
2	10	120	0.5	120,000
3	10	240	1	120,000
4	10	360	1.5	120,000
5	10	480	2	120,000
6	20	60	0.25	120,000
7	20	120	0.5	120,000
8	20	240	1	120,000
9	20	360	1.5	120,000
10	20	480	2	120,000
11	25	60	0.25	120,000
12	25	120	0.5	120,000
13	25	240	1	120,000
14	25	360	1.5	120,000
15	25	480	2	120,000

the same with a precision tooling set. However, when a tool is changed, the origin coordinate of the Z axis is lost, and resetting the relative Z axis coordinate takes significant time and effort. Current available commercial touch probes are not capable of handling micro-scale resolution. Therefore, it is critical to find a reliable and easy method for setting the reference point. In this study, an AE sensor was built and preliminary tests demonstrated promising results. This detection system is easy to set up and has a high sensitivity because the sensor mounting and other setup procedures cannot interrupt the machining set up.

4. Results and discussion

4.1 The relationship between surface topography and cutting parameters

Fig. 5 shows the effects of the feed per tooth f_t (uncut chip thickness) and the axial depth of cut A_d on the surface roughness for down-milling. For AISI D2 steel, the surface roughness (R_a) values vary in the range of 50 nm up to 850 nm. For an A_d of 20 μm (0.1 D), the surface roughness generally increases with f_t and was the lowest at the optimum f_t of 0.25 μm . Fig. 5 also shows that the A_d has influences on the surface roughness. For A_d of 20 μm (0.1 D), the effect of f_t on the surface roughness is different from the others because the width of the uncut chip changed. Meanwhile, Fig. 6 shows the machined

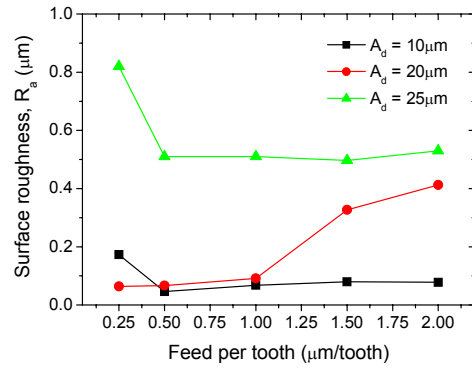
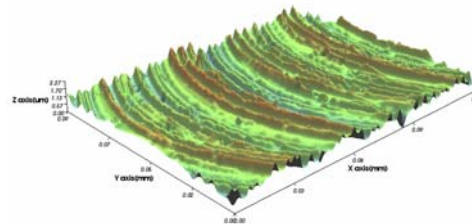
Fig. 5. The relationship between R_a and f_t .

(a) Three-dimensional machined surface

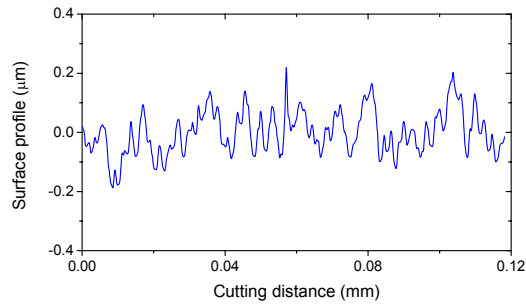

(b) Two-dimensional machined surface

Fig. 6. Machined surface topography.

surface topography at f_t of 0.25 μm and A_d of 10 μm (0.05 D). For other A_d values (0.05 D, 0.125 D), the effect of f_t on the surface roughness is not obvious as f_t exceeds 0.5 μm for a larger A_d . At higher f_t values, the surface roughness values all tend toward a constant value and are the lowest at the optimum f_t of 0.5 μm . A low ratio of the feed per tooth to the cutting edge radius (f_t/r_c) influences the surface topography. When this ratio is too low, the ploughing at the cutting edge action dominates instead of the shearing action. This results in a relatively large fraction of the material, corresponding to the uncut chip volume, bulging to the side and in front of the cutting edge, remaining attached to the milled surface, and appearing as burrs.

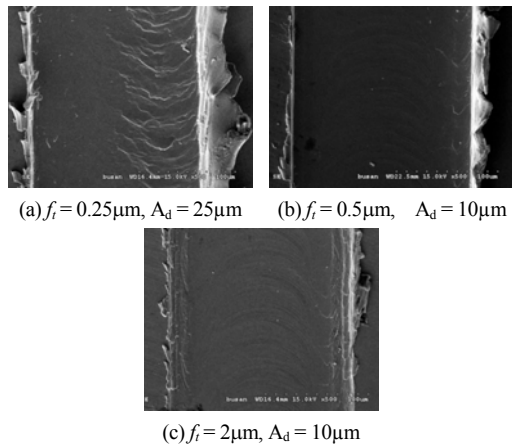

Fig. 7. SEM pictures of the machined surface.

Fig. 7 shows the SEM pictures of the machined surfaces with burrs visible on the top edges. The burr size of the left side is larger than the right side because the right side is in an up-milling state. Likewise, a low f_i/r_c increases the burr size and surface roughness. The increase of the rounding radius with the tool wear further increases the extent of the ploughing action along the slot, but this higher surface roughness might not be acceptable in the manufacturing of micro parts. When f_i is too small (0.25 μm), the surface roughness is increased because the effective rake angle at the cutting edge becomes negative due to a lower f_i/r_c (< 1), which causes ploughing with the elastic recovery instead of the shearing [13]. On the other hand, cutting efficiency is best when f_i is 1 μm . The process parameters are optimized to reduce the burr size and improve the tool life. The spindle speed is 120,000 rpm, f_i is 1 μm , and A_d is 10 μm with an achievable surface roughness of 0.06 $\mu\text{m} R_a$.

Due to a low f_i/r_c , both high surface roughness and high burrs are obtained during micro-milling. The overall improvement of the process performance could be obtained, in principle, by increasing f_i/r_c . In general, r_c has to be smaller to improve the surface quality. However, it is difficult to reduce r_c , but it is possible to increase f_i by increasing the feed rate. The increase in f_i/r_c would lead to a beneficial value of the average rake angle and improve the material removal geometry.

4.2 The relationship between cutting forces and cutting parameters

Fig. 8 shows the relationship between the experi-

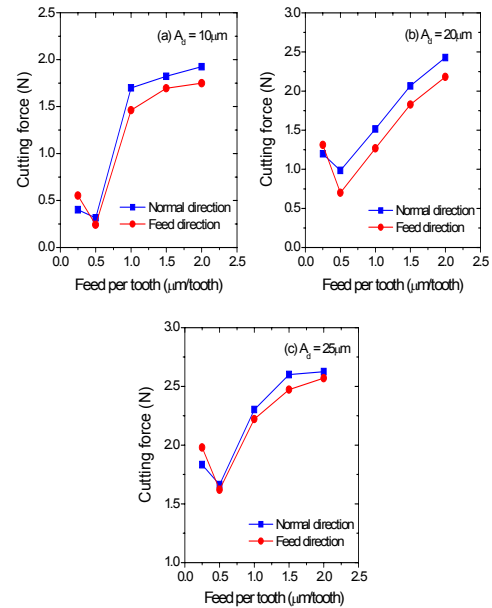

Fig. 8. The relationship between cutting forces and f_i .

mental feed direction and the normal direction cutting forces at the spindle speed of 120,000 rpm according to the increase in A_d . The cutting forces at f_i of 0.25 μm are larger than that of f_i of 0.5 μm , and the cutting forces above f_i of 0.5 μm increase rapidly. This value is the transition point for the cutting forces. The transition of the cutting force is observed according to the increase in A_d . According to literature, the minimum uncut chip thickness is about 40% of r_c [14, 15]. Therefore, these results indicate that the sliding and the ploughing at the cutting edge increase the cutting forces for a smaller f_i due to a lower $f_i/r_c = 0.25$. In addition, it is shown that the magnitude of the cutting forces increases as A_d increases at the same f_i . The main reason for this trend is that the increase in the chip cross-sectional area would lead to higher total cutting forces.

Fig. 9 shows the variations of the forces in the X, Y, and Z directions for a single rotation of the milling tool. The spindle speed is 120,000 rpm, meaning that the time scale associated with each revolution is 0.5 ms. The cutting parameters are f_i of 0.5 μm and A_d of 20 μm . The normal direction cutting forces are higher than those of the feed and axial direction cutting forces. In micro machining, the cutting forces are smaller compared with conventional machining, and it can be seen from the Fig. that the cutting force gradually increases at each cycle. The gradual increase in the cutting force reveals that the tool wears

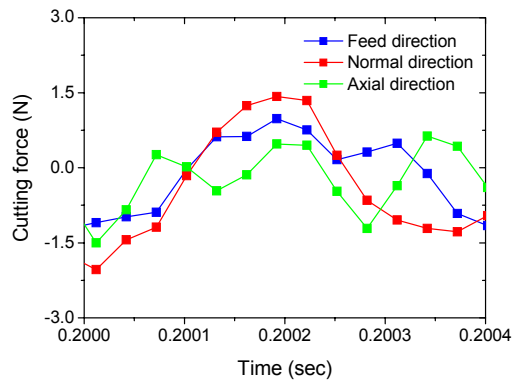

Fig. 9. Cutting force for a single rotation in micro-milling.

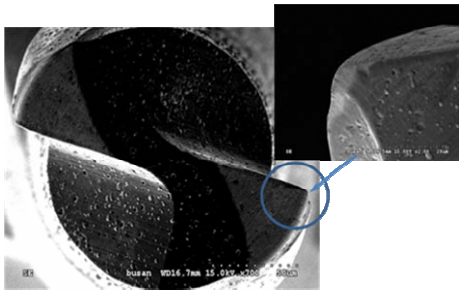

Fig. 10. SEM pictures of micro-milling tool wear: $f_t = 2\mu\text{m}$, $A_d = 20\mu\text{m}$, cutting length = 20mm.

as the cutting progresses, which can be clearly observed from the cutting force. The chipping of the cutting edge has also been observed during micro-milling experiments, as shown in Fig. 10. This indicates that the chips of the work-piece material either might have clogged the flutes before they were deposited on the surface of the work piece in the next engagement of the tooth or led to the breakage of the cutting tool.

5. Conclusions

This study conducts micro-milling of AISI D2 steel using two-flute WC micro-milling tools at various cutting conditions. The characteristics of the cutting forces and the surface topography are also investigated.

The cutting forces are small in micro-cutting while the radial thrust cutting forces are greater than the principal cutting forces in micro-milling of AISI D2 steel. A low ratio of the feed per tooth to the cutting edge radius increases the burr size and surface roughness. The determination of the cutting parameters for micro-milling should be based on the surface topog-

raphy and cutting force, taking into account the role of the cutting edge radius. The solution is proposed consisting of the increase in the feed per tooth. Afterwards, the implications on the cutting force components are evaluated. As the ratio of the feed per tooth to the cutting edge radius is larger than 1.0, the surface roughness values all tend towards a constant value, while the cutting forces rapidly increase. When the feed per tooth is less than the minimum uncut chip thickness, the sliding and the ploughing at the cutting edge increase the cutting forces due to the lower ratio of the feed per tooth to the cutting edge radius. Moreover, an AE sensor is used to find the relative position of the tool and work piece for improving the dimensional accuracy, reliability, and easy set up of the micro-tools.

Acknowledgment

This paper is financially supported by Engineering Research Center for Net Shape and Die Manufacturing, Pusan National University, Republic of Korea.

References

- [1] G. Bissacco, H. N. Hansen and J. Slunsky, Modeling the cutting edge radius size effect for force prediction in micro-milling, *CIRP Ann-Manuf. Technol.* 57 (2008) 113-116.
- [2] J. Chae, S. S. Park and T. Freiheit, Investigation of micro-cutting operations, *Int. J. Mach. Tools Manufact.* 46 (2006) 313-332.
- [3] K. C. Chan, C. F. Cheung, M. V. Ramesh and W. B. Lee, A theoretical and experimental investigation of surface generation in diamond turning of an Al6061/SiCp metal matrix composite, *Int. J. Mech. Sci.* 43 (9) (2001) 2047-2068.
- [4] S. Katayama, M. Toda and M. Hashimura, Growth model of built-up edge based on inhomogeneities in microstructure of steel, *Int. J. for JSPE* 31 (1997) 15-20.
- [5] J. D. Kim and D. S. Kim, Theoretical analysis of micro-cutting characteristics in ultra-precision machining, *J. Mater. Process. Technol.* 49 (1995) 387-398.
- [6] I. S. Kang, J. S. Kim, J. H. Kim, M. C. Kang and Y. W. Seo, A mechanistic model of cutting force in the micro end milling process, *J. Mater. Process. Technol.* 187-188 (2007) 250-255.
- [7] I. S. Kang, J. S. Kim and Y. W. Seo, Cutting force

- model considering tool edge geometry for micro end milling process, *J. Mech. Sci. Technol.* 22 (2008) 293-299.
- [8] I. N. Tansel, T. T. Arkan, W. Y. Bao, N. Mahendrakar, B. Shisler, D. Smith and M. McCool, Tool wear estimation in micro-machining. Part I: tool usage-cutting force relationship, *Int. J. Mach. Tools Manufact.* 40 (2000) 599-608.
- [9] X. M. Lai, H. T. Li, C. F. Li, Z. Q. Lin and J. Ni, Modeling and analysis of micro scale milling considering size effect, micro cutter edge radius and minimum chip thickness, *Int. J. Mach. Tools Manufact.* 48 (2008) 1–14.
- [10] G. Bissacco, H. N. Hansen, J. Fugl, P. T. Tang and L. De Chiffre, Manufacturing of an injection moulding mould insert with three dimensional micro features by micromilling, *Proc. 5th Euspen International Conference*, Montpellier, France (2005) 505-508.
- [11] G. Bissacco, H. N. Hansen and L. De Chiffre, Micromilling of hardened tool steel for mould making applications, *J. Mater. Process. Technol.* 167 (2005) 201-207.
- [12] J. Manjunathaiah and W. J. Endres, A study of apparent negative rake angle and its effects on shear angle during orthogonal cutting with edge-radiused tools, *Trans. NAMRI/SME* 28 (2000) 197-202.
- [13] Z. J. Yuan, M. Zhou and S. Dong, Effect of diamond tool sharpness on minimum cutting thickness and cutting surface integrity in Ultraprecision Machining, *J. Mater. Process. Technol.* 62 (1996) 327-330.
- [14] C. J. Kim, J. Rhett Mayor and J. Ni, A static model of chip formation in micro scale milling, *J. Manuf. Sci. Eng.-Trans. ASME* 126 (2004) 710-718.
- [15] M. P. Vogler, R. E. DeVor and S.G. Kapoor, Microstructure-level force prediction model for micro-milling of multi-phase materials, *J. Manuf. Sci. Eng.-Trans. ASME* 125 (2) (2003) 202-209.



Cheng-zhe Jin is currently an associate professor of Machining Technology Center at Shenyang Ligong University. He received his Ph.D. degree in Mechanical Engineering from Beijing Ligong University in 2003. He joined Pusan National University as a Post Doc. from 2008 to 2009. His research interests include high speed machining, machine tools, machining automation and surface engineering.



Jeong-Suk Kim is currently a professor of School of Mechanical Engineering at Pusan National University. He received his Ph.D. degrees in Mechanical Engineering from Korea Advanced Institute of Science and Technology in 1991. His research interests include high speed machining, micro machining, machine tools dynamics, machinability evaluation and machining process monitoring.